

In this instruction, we will omit the part marked with ©Nintendo ©HANAYAMA to make the internal movements easier to understand.

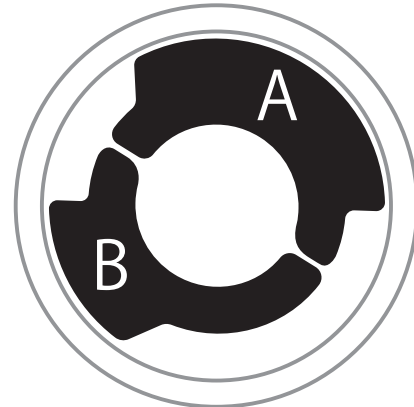

The pieces are represented by A and B as above.

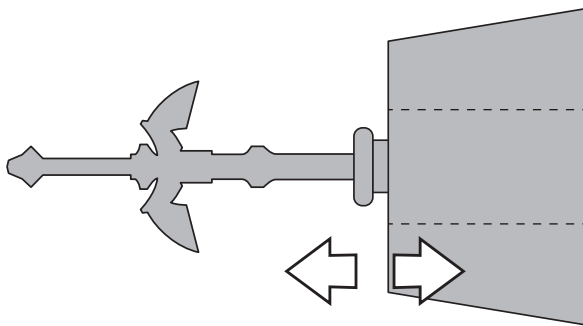

Hold the puzzle horizontally and rotate, push, or pull out the center piece.



Push and Pull until the movement stops.

① From starting position, rotate counterclockwise until it stops.



② Push in A and turn counterclockwise until it stops.

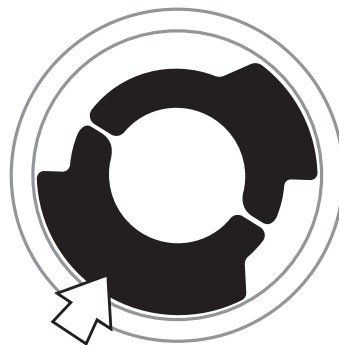

③ Push in both A and B and turn counterclockwise until it stops.

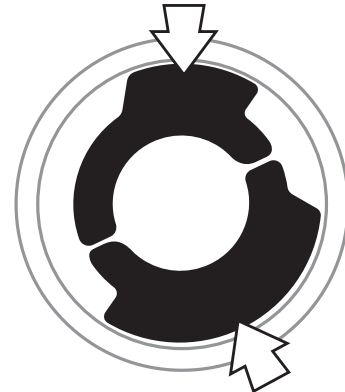

④ Push in A and turn counterclockwise until it stops.

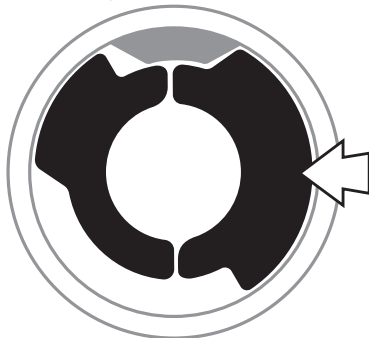

⑤ Push in B and turn clockwise until it stops.



⑥ Pull A toward you and turn it clockwise until it stops.

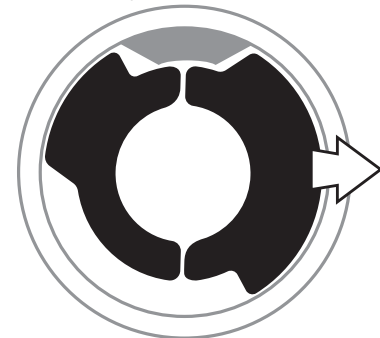

⑦ Pull A toward you and turn it clockwise until it stops.



⑧ Pull A and B toward you and turn them clockwise until they stop.

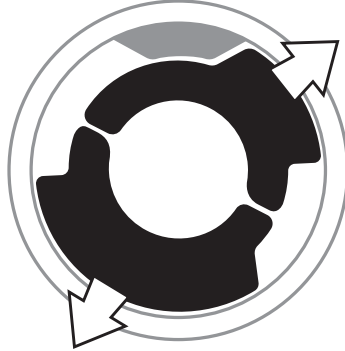

⑨ Push in A and turn counterclockwise until it stops.

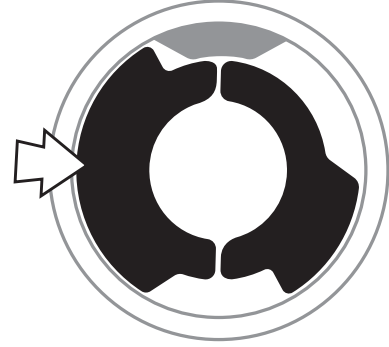

⑩ Push in A and B and turn counterclockwise until they stop.



⑪ Pull B one step up and turn it clockwise until it stops.

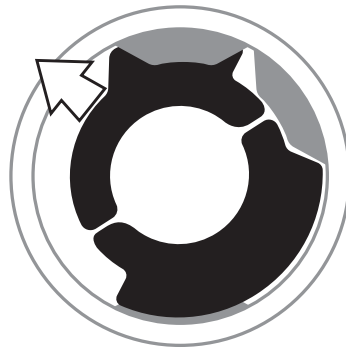

⑫ Pull A and B up and turn clockwise until they stop.

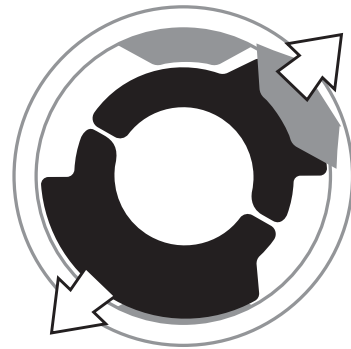

⑬ Push in A and turn clockwise until it stops.



⑭ Push in A and turn counterclockwise until it stops.



⑮ It will come off in this position. Reverse the steps to reassemble.

